

LOC	DIST	P	F	ZONE	LTR	REVISIONS	DATE	APPD
AJ	16				N	REV PER OU20-0235-99	02FEB00	MO

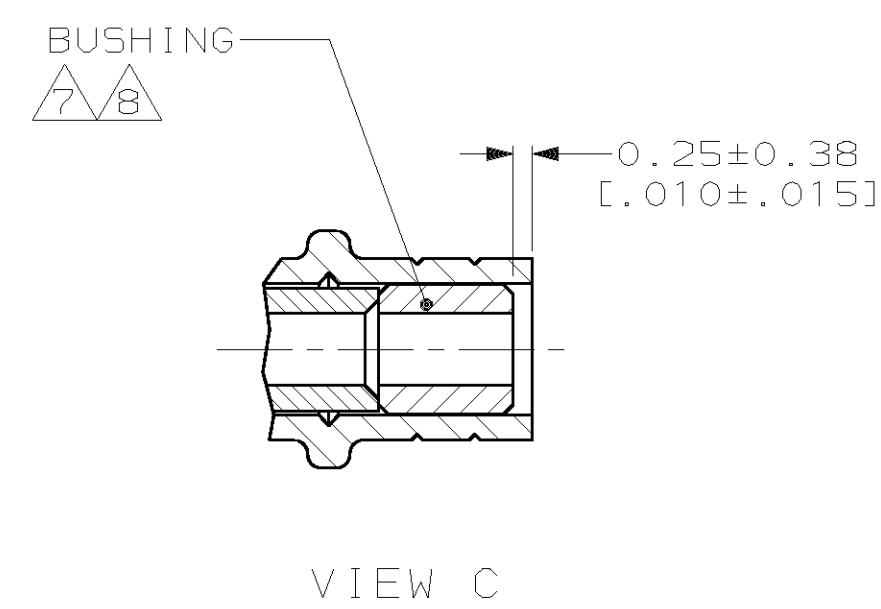
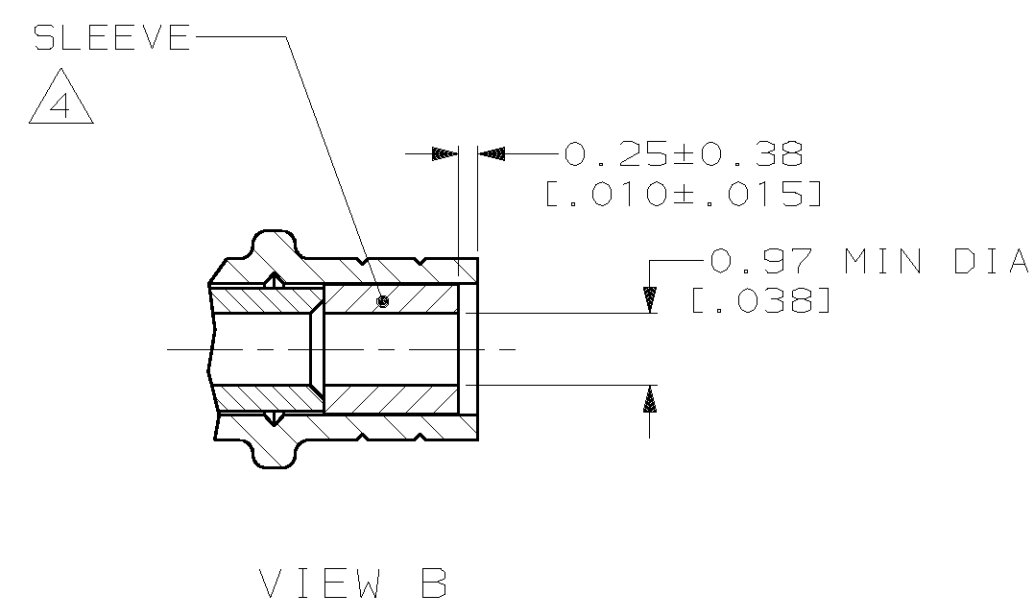
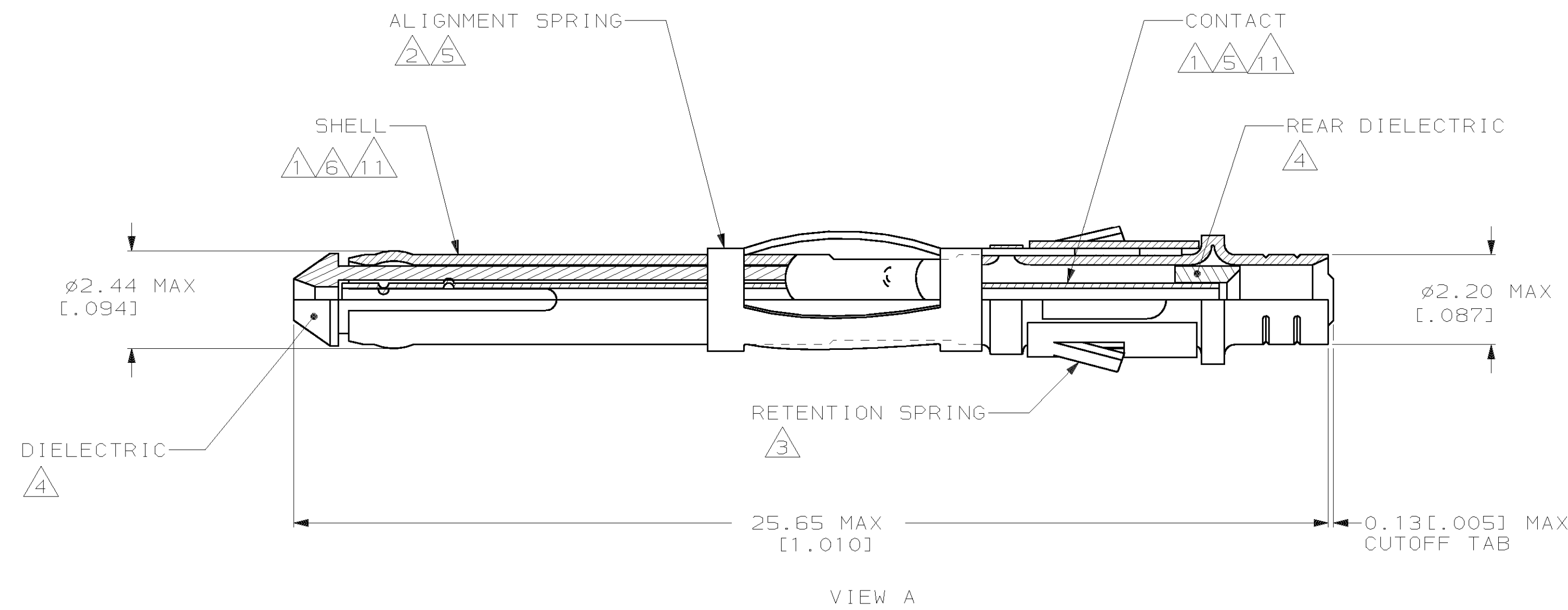

- 1 GOLD PL PER MIL-G-45204, .000030 ON MATING SURFACES, FLASH ON REMAINDER
- 2 NICKEL PL PER QQ-N-290
- 3 STAINLESS STEEL PER QQ-S-766
- 4 POLYPROPYLENE OR POLYMETHYLPENTENE GENERAL PURPOSE
- 5 BERYLLIUM COPPER PER QQ-C-533
- 6 BRASS PER MIL-C-50
- 7 BRASS PER ASTM-B-135
- 8 TIN PL PER MIL-T-10727
- 9. WEIGHT: .016 OZ
- 10. FOR CABLE SELECTION, FERRULE AND HANDTOOL PART NUMBERS, SEE I.S. 2024-2
- 11 GOLD PL PER MIL-G-45204, .000050 ON MATING SURFACES, FLASH ON REMAINDER

OBSOLETE	A	1, 2	3, 4, 5, 6	226537-7
OBSOLETE	C	1, 2, 8	3, 4, 5, 6, 7	226537-6
OBSOLETE	B	1, 2	3, 4, 5, 6	226537-5
	A	1, 2	3, 4, 5, 6	226537-4
	C	1, 2, 8	3, 4, 5, 6, 7	226537-3
	B	1, 2	3, 4, 5, 6	226537-2
	A	1, 2	3, 4, 5, 6	226537-1
VIEW	FINISH	MATERIAL	PART NUMBER	

DO NOT SCALE PRINT. UNLESS SPECIFIED DIMENSIONS IN mm [INCHES]		DR 7-23-91 S.D. KOHL		AMP Incorporated Harrisburg, PA 17105-3508	
2 PLC DEC ± -	APPD 8-1-91 D. DOYE	NAME	PIN ASSY, SERIES SUBMINIATURE		
3 PLC DEC ± -	APPD 8-3-91 B. WERNER	PRODUCT SPEC	-		
ANGLES ± -	APPLICATION SPEC	FINISH	SIZE D	CAGE CODE 00779	DRAWING NO 226537
SEE TABLE	SEE TABLE	SCALE 10:1	SHEET 1 OF 1		